

Fixed from the bottom side with 4x M8 screws, sliding screw-nuts are included

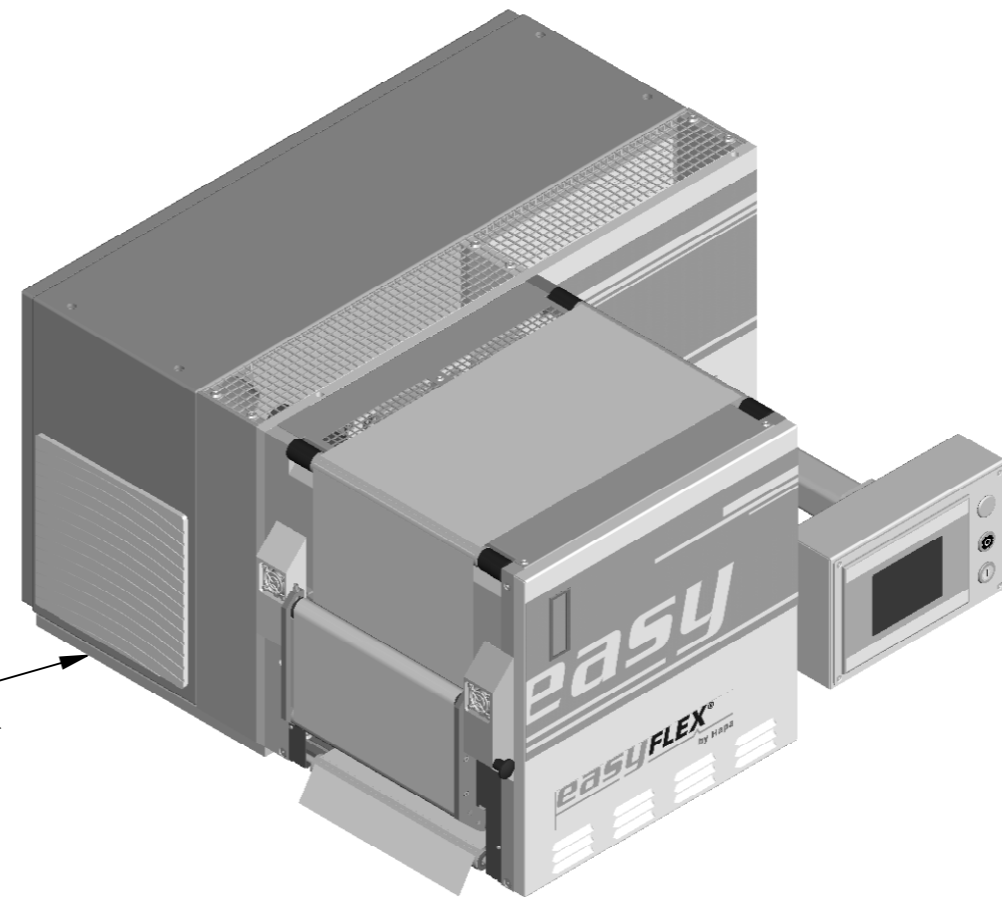
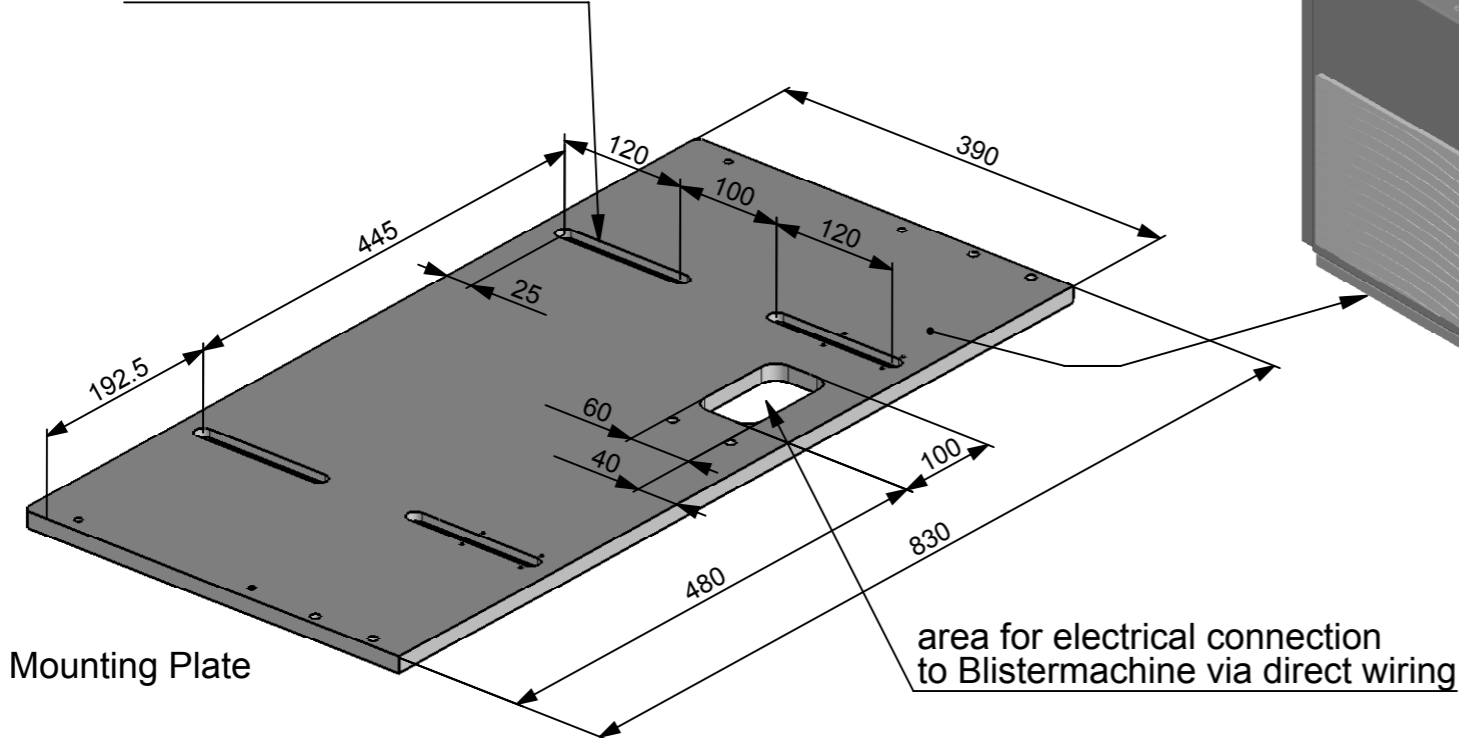

Performance:

- max. foil width 270 mm
- max. print area 260x180 mm
- max. print cycles 65 cycles/min
- max. foil speed 11.7 m/min

Electrical specifications:

- voltage 400V/50Hz - 480V/60Hz
- fuse protection 20 A
- el. connection 3 phase and earth
- peak capacity 4.5 kVA
- average power consumption 2 kW

weight approx. 230 kg

Working mode:
intermittent or continuous

Erstell-Datum	Name	Änd.-Nr.	12.02.2009	Bezeichnung	EasyFlex byHAPA	
12.02.2009	hol		hol	Zeichnungs-Nr.	D-626-111002-en	Index
			FORMAT	MASSTAB		
			A3	1:6		